

Miss Baker® PRO XL: technical data

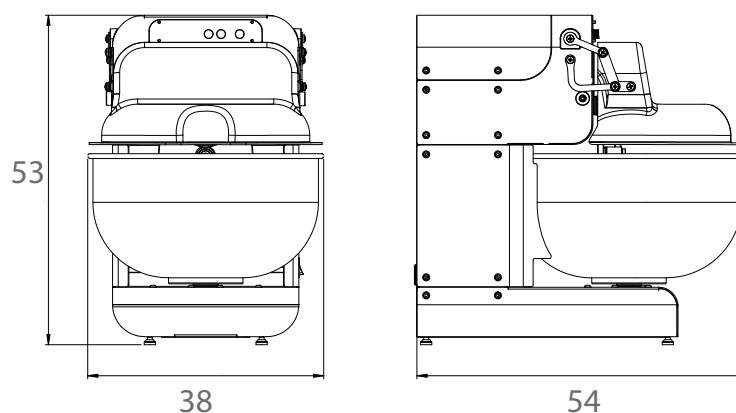

Maximum dimensions (cm) of Miss Baker® PRO XL

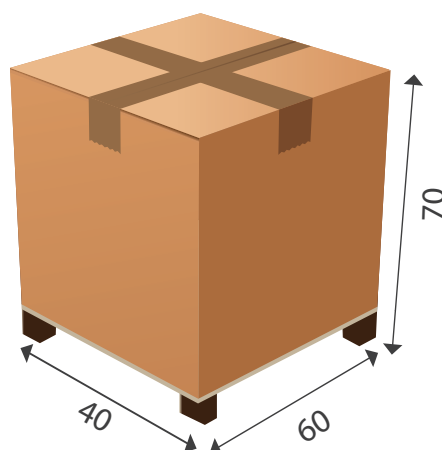

| Miss Baker® PRO XL | |
|---|---------------------------|
| Flour capacity | 1 - 3,5 kg |
| Kneading capacity* | 1,5 - 8 kg** |
| Bowl capacity | 20 liters |
| Dimensions of bowl | Ø 36 - h 20 |
| Voltage | 230 V single-phase |
| Power | 500 W |
| Speed of the arms | from 35 to 70 strokes/min |
| Kneading machine dimensions LxPxH (cm) | 38x54x53 |
| Dimensions with packaging LxPxH (cm) | 40x60x70 |
| Kneading machine weight / Weight with packaging | 39 kg / 51 kg |
| Code | MS0623059 |

* The kneading capacity refers to a flour / liquid ratio of 1:0.6 and may vary according to the recipe

** The maximum kneading capacity refers to very hydrated doughs and for large leavened products. For hard doughs - hydration less than 55% - such as egg pasta and sourdough, reduce the maximum flour capacity by 50%.