

MULTISYSTEM 60-80-100-140

Celle frigorifere a modularità integrale
Fully modular cold rooms
Chambres froides à modularité intégrale
Modulare aufgebaute Kühlzellen

PG. 2

Multisystem è una gamma di celle frigorifere modulare ed estensibile. La sua modularità e completezza di accessori consentono la realizzazione sempre "agganciata" di configurazioni sia semplici che complesse, è modificabile per evoluzioni future e permette l'utilizzo di poche tipologie di pannelli per un grande numero di dimensioni di celle agevolando quei distributori che lavorano a stock di componenti.

Multisystem is a range of fully modular and extendable cold rooms. Its modularity and the complete range of accessories permit the assembling with camlocks of simple and complicated project, can be extended / partitioned for future needs and permits the use of just a few different types of panels for a large number of cold-rooms dimensions facilitating those distributors who work with stock of panels.

Multisystem est une gamme de chambres frigorifiques modulable et extensible. Sa modularité et les nombreux accessoires disponibles permettent la réalisation toujours "accrochée" de configurations soit simples que complexes, elle est modifiable pour des évolutions futures et permet l'utilisation de peu de types de panneaux pour un grand nombre de dimensions de chambres froides en facilitant les distributeurs qui travaillent à stock de composants.

Multisystem ist eine Auswahl an modularen und erweiterbaren Kühlzellen. Ihre Modularbauweise und ihre Vollständigkeit an Zubehör ermöglichen die Ausführung immer durch Hacken von sowohl einfachen als auch komplexen Aufbauten, sie ist für zukünftige Entwicklungen veränderbar, und sie ermöglicht, durch den Gebrauch von wenigen Paneeltypologien zahlreiche Größen von Kühlzellen zu erhalten, was insbesondere für Absatzhändler, die mit Komponentenvorräten arbeiten, vorteilhaft ist.



MULTICABINET 60-100

Armadi Frigoriferi Componibili
Refrigerated cabinet elements
Armoires Frigorifiques à Éléments
Zusammenbaubare Kühlschränke

PG. 16



CE
ETA 09/0066

B-s3,d0
EN 13501-1

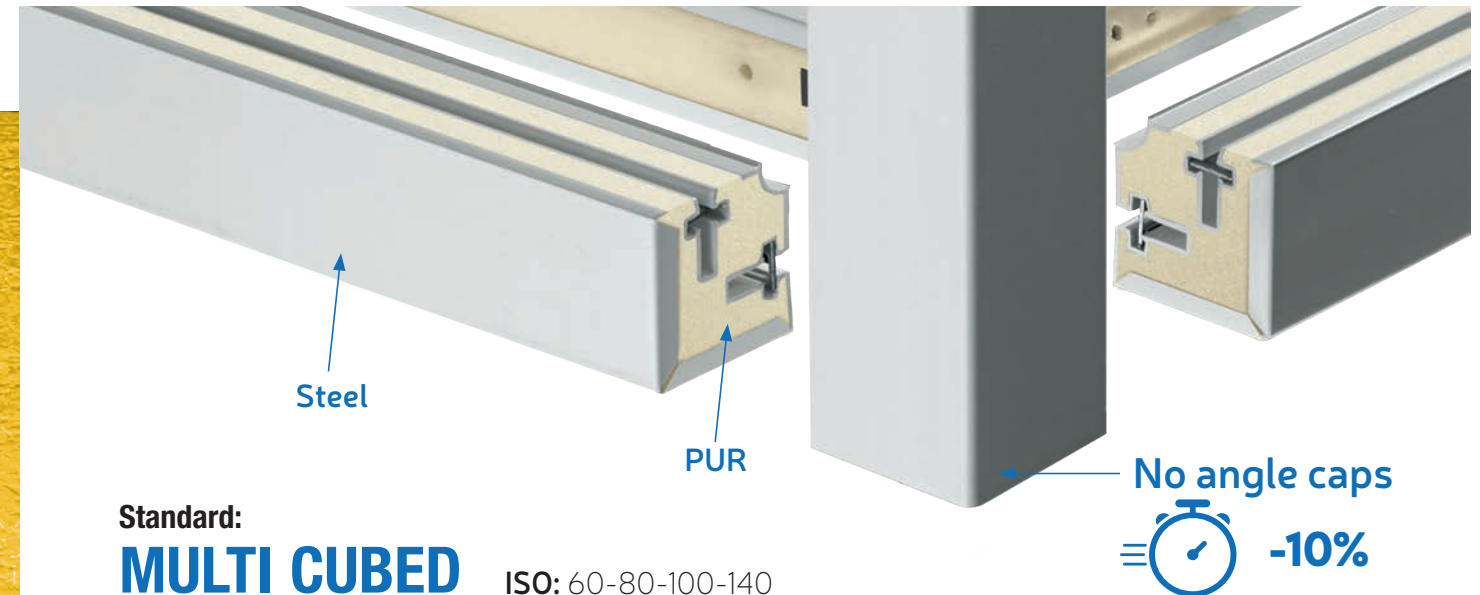

Standard:
MULTI CUBED ISO: 60-80-100-140

Cella frigorifera con angolare composto da 2 gusci in lamiera con poliuretano interno e sistema d'aggancio universale.
Cold room with edge profile consisting of 2 shells in sheet metal with polyurethane on the inside and universal connection system.
Chambre froide avec poteau d'angle composé de 2 coques en tôle avec polyuréthane intérieur et système d'accrochage universel.
Kühlzelle mit Eckprofil bestehend aus 2 mit Polyurethan gefüllten Blechschalen und einem universellem Befestigungssystem.

Options:

MULTI L

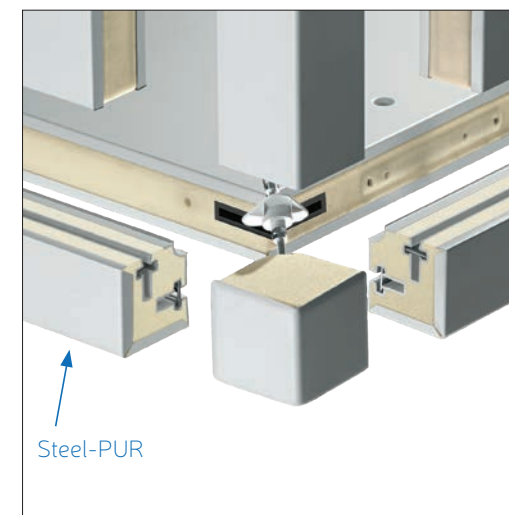

ISO: 60-80-100-140

MULTI

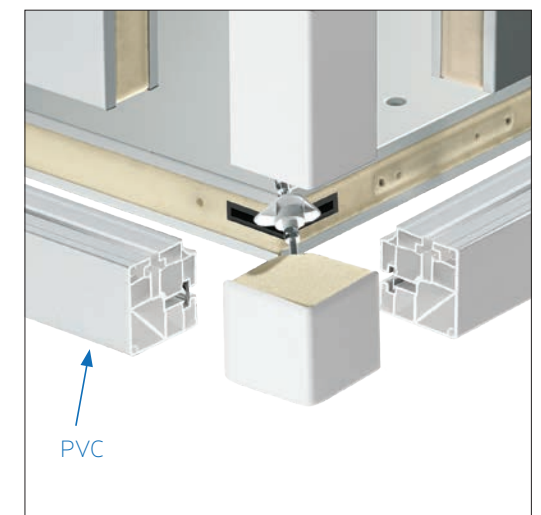

ISO: 60-80-100

PANNELLO MULTI Panels - Panneaux - Paneele



Tipo sandwich con due supporti metallici con interposta schiuma di poliuretano (PUR) rigida.
Lamiere zincata preverniciata 30 microns, colore bianco RAL 9010, atossica, con pellicola protettiva temporanea.
Classe di reazione al fuoco standard: B s3 d0 secondo norma europea EN 13501-1 equivalente alla classe 2 secondo norma UNI 9177.

Sandwich panels consisting of rigid polyurethane foam (PUR) inside 2 metal sheets. Pre-painted galvanized steel sheet with 30 microns of paint, with colour RAL 9010, non toxic, with temporary protective film.
Reaction to fire, B s3 d0 according to European standard EN 13501-1 corresponding to class 0 according to BS 476 Parts 6 & 7.

Panneau sandwich constitué de deux parements métalliques et d'un noyau de mousse de polyuréthane (PUR) rigide.
Tôle galvanisée pré-laquée 30 microns, de couleur blanc RAL 9010, atoxique, avec film de protection temporaire.
Classe de réaction au feu standard: B s3 d0 selon norme Européen EN 13501-1 correspondant à la classe M1 selon NF P92-507.

Sandwichpaneelle bestehend aus 2 Metallunterlagen mit hartem Polyurethanschaum (PUR). Verzinktes lackiertes ungiftiges Blech 30 Mikrons, Farbe weiß RAL9010, mit wegnehmbarer Schutzfolie.
Standard Feuerreaktionsklasse: B s3 d0 gemäß der europäischen Norm EN 13501-1 entsprechend der B1 Klasse gemäß der DIN-Norm 4102.

ISO: mm 60-80-100-140
MODUL: mm 200 (Option mm 100)
H int.: mm 2030-2230-2430-2630-2830-3030-3230
Isolamento - Insulation - Isolation - Isolierung
PUR - 41 kg/m³ - λ 0,023 W/mK
Reaction to fire B s3 d0 standard

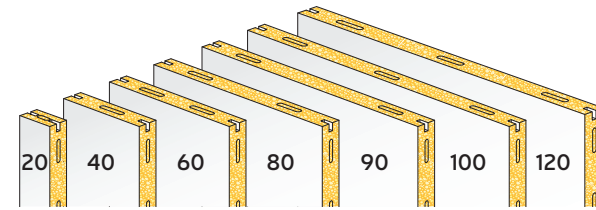

PORTE Doors - Portes - Türen



CE-MULTI

Maniglia con chiave e sblocco interno di sicurezza luminescente.
Handle with key and inside luminescent safety release.
Poignée avec clé et déblocage intérieur de sécurité luminescent.
Griff mit Schlüssel und innerem leuchtendem Notentriegelung.

PG. 10



Option: SC-MULTI

Option:
Serratura con chiave
Key lock
Serrure à clé
Schloss mit Schlüssel

PG. 12

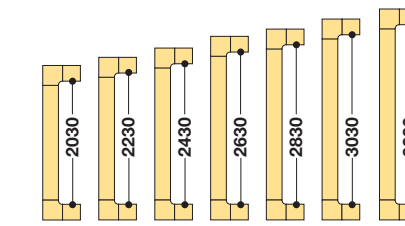

7 ALTEZZE
7 Heights
7 Hauteurs
7 Höhen

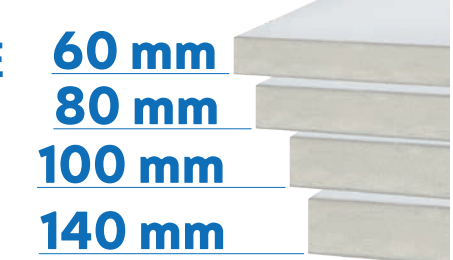

60 mm
80 mm
100 mm
140 mm

4 SPESSORI
4 Thicknesses
4 Epaisseurs
4 Stärken

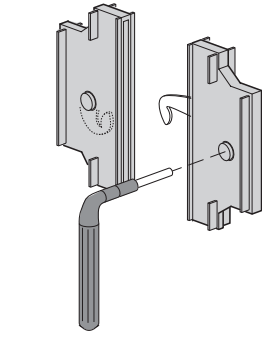

UNIONE CON GANCI ECCENTRICI A DOPPIO EFFETTO

Connection with dual effect camlocks
Union par crochets excentriques à double effet
Verbindung mit exzentrischen Doppelleffektaken



ANGOLI INTERNI ARROTONDATI R15

Rounded R15 internal corners
Angles intérieurs arrondis R15
Abgerundete Innenecken R15

IN-LINE SYSTEM

Nuovo sistema per un rapido e preciso allineamento tra pannelli e giunti d'angolo. Aumenta, inoltre, la portata del soffitto e ne facilita il montaggio.

New system for rapid and accurate alignment between panels and corner joints. Also increases the load capacity of the ceiling and facilitates assembly.

Nouveau système pour un alignement rapide et précis entre les panneaux et les joints d'angle. Il augmente, en outre, la capacité du plafond et il facilite son assemblage.

Neues System für ein schnelles und präzises Ausrichten von Wandelementen und Eckverbindungen. Es erhöht ferner die Tragfähigkeit der Decke und erleichtert die Montage.



P 90 - PAVIMENTO Floor - Sol - Boden

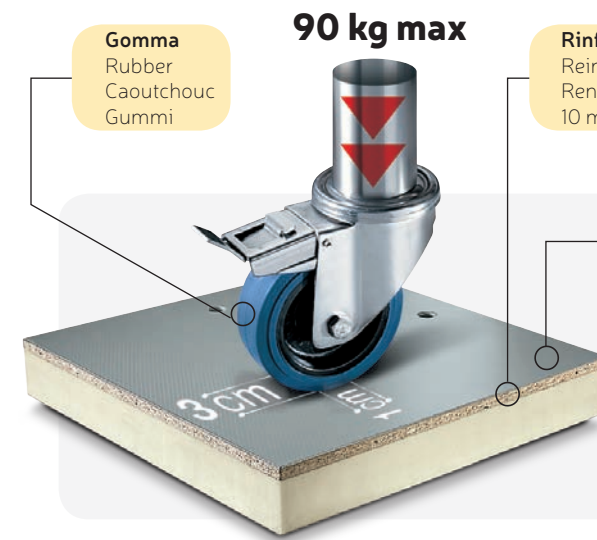

90 kg max
Gomma
Rubber
Caoutchouc
Gummi

Rinforzo in truciolare spessore 10 mm.
Reinforced with chipboard for a thickness of 10 mm.
Renforcement en bois aggloméré épaisseur 10 mm.
10 mm starker Spanverstärkung plastifiziert.

Lamiere di acciaio zincato, plastificata con film in PVC rigido 200 micron.
Galvanized sheet steel with grey plastic coating in rigid PVC film 200 micron thick.
Tôle d'acier galvanisée, plastifiée avec film en PVC rigide 200 micron.
Trittfläche aus verzinktem Stahlblech, mit einem harten 200 micron starken, grauen, rutschfesten PVC - Film.

Options PG. 6

CELLE SENZA PAVIMENTO

Cold rooms without floors
Chambres sans sol
Kühlzellen ohne Boden

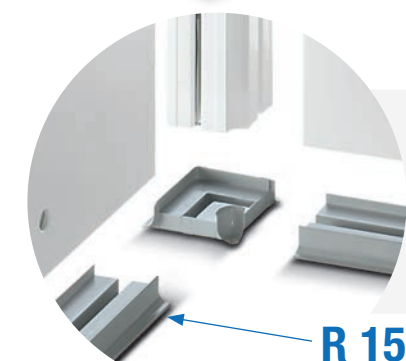

R 15

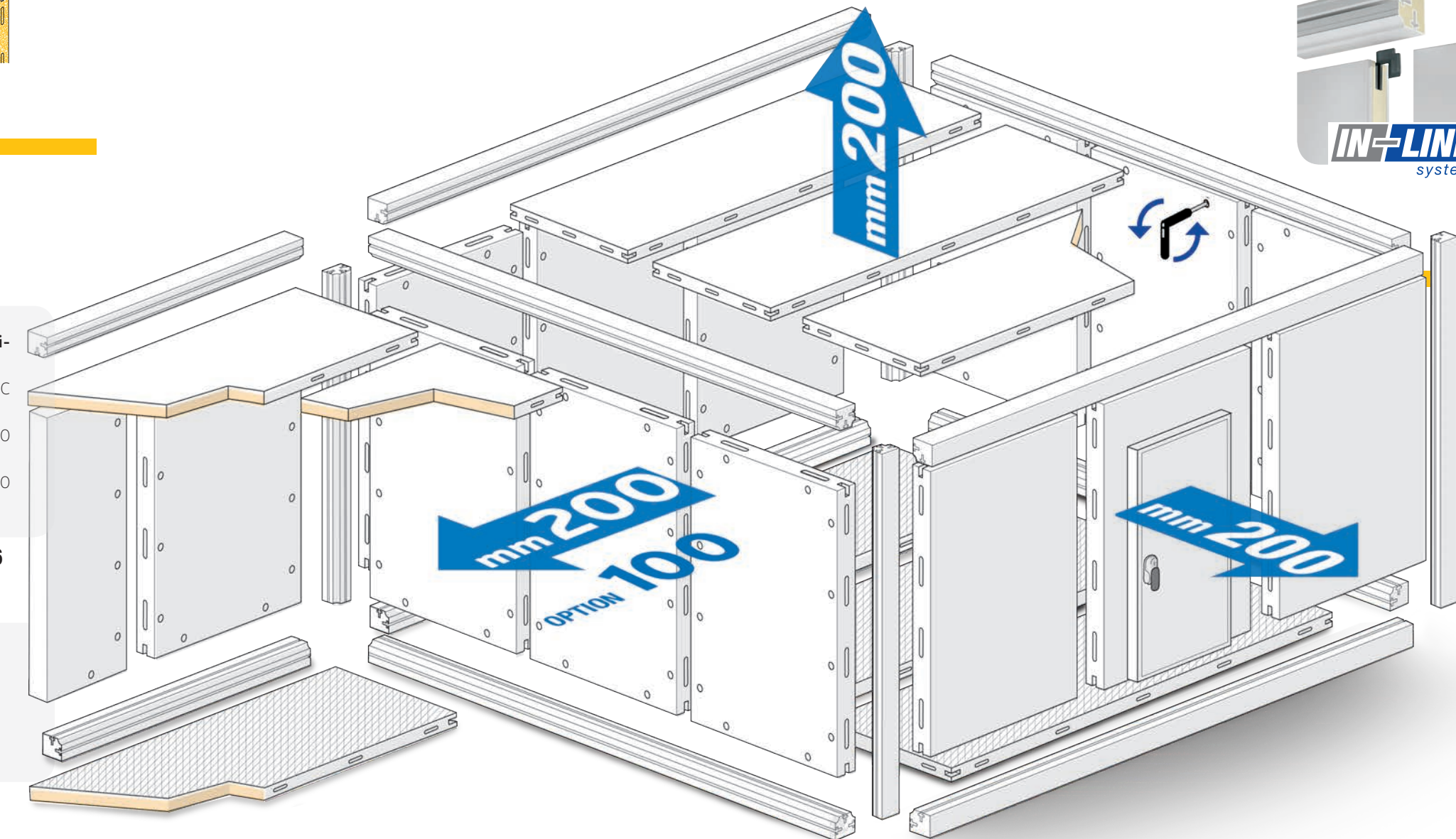

ANGOLARI Edge profiles - Poteaux d'angle - Eckprofile

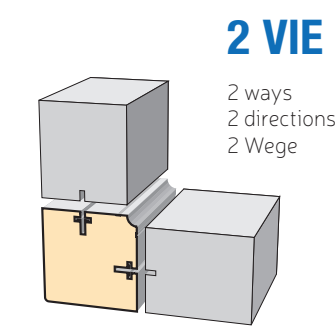

2 VIE
2 ways
2 directions
2 Wege

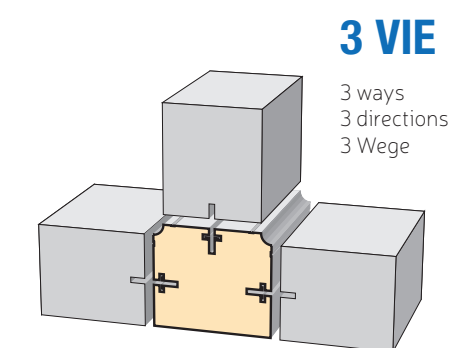

3 VIE
3 ways
3 directions
3 Wege

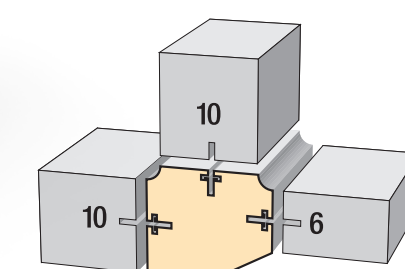

3 VIE RACCORDATO
3 way connection
3 directions raccordé
3 Wege verbunden

Options: RIVESTIMENTI Panel finishing - Revêtement - Beschichtung

PL

Lamiera Plastificata
Plasticized sheet metal
En tôle Plastifiée
Kunststoffbeschichtetes Stahlblech

Lamiera di acciaio zincato, plastificato con film in PVC rigido dello spessore di 120 micron bianco, atossico con pellicola protettiva.

Galvanized sheet steel with plastic coating in rigid white PVC 120 micron thick, non-toxic, with protective film.

Tôle d'acier galvanisée plastifiée avec film en PVC rigide d'épaisseur de 120 micron blanc, atoxique avec pellicule de protection.

Verzinktes Stahlblech, mit weißem, hartem, ungiftigem und 120 micron starkem PVC- Film plastifiziert, mit Schutzfilm.

IX

Lamiera Inox
Stainless steel sheet
Tôle Inox
Edelstahlblech

Lamiera INOX AISI 304, finitura scOTCH brite con pellicola protettiva.

AISI 304 stainless sheet steel, finished with Scotch-Brite treatment with protective film.

Tôle INOX AISI 304, finition SCOTH BRITE avec pellicule de protection.

Blech aus CHROMNICKELSTAHL 1.4301, Scotch- Brite- Oberflächenausführung mit Schutzfilm.

PX

Lamiera Inox Plastificata
Plasticized stainless steel sheet metal
En tôle Inox Plastifiée
Kunststoffbeschichtetes Edelstahlblech

Lamiera INOX AISI 304, plastificato con film di PVC rigido dello spessore di 120 micron bianco, atossico con pellicola protettiva.

AISI 304 stainless sheet steel with plastic coating in rigid white PVC 120 micron thick, non-toxic, with protective film.

Tôle INOX AISI 304, plastifiée avec film en PCVC rigide l'épaisseur de 120 micron blanc, atoxique avec pellicule de protection.

Blech aus CHROMNICKELSTAHL 1.4301 mit weißem, hartem, ungiftigem und 120 micron starkem PVC- Film plastifiziert, mit Schutzfilm.

SANISTEEL

Lamiera Plastificata Antibatterica
Antibacterial Plasticized sheet metal
En tôle Plastifiée antibactérienne
antibakterielle Kunststoffbeschichtetes Stahlblech

Lamiera di acciaio zincato, plastificato con film in PVC antibatterico.

Galvanized sheet steel with antibacterial plastic coating PVC.

Tôle d'acier galvanisée plastifiée avec film en PVC antibactérien.

Verzinktes, kunststoffbeschichtetes Stahlblech mit antibakteriellem PVC-Film.



Options: PAVIMENTI Floors - Sols - Bodenelemente

90 kg max

P 90 IX

INOX AISI 304, antisdrucciolo con certificato R12

AISI 304 stainless steel, non-slip with R12 certificate

INOX AISI 304, antidérapant certifié R12

Rutschfester CHROMNICKELSTAHL 1.4301 mit R12- Zertifikat

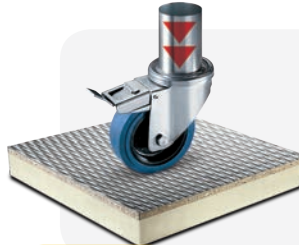

Ruota rigida
Rigid wheel
Roue rigide
hartem Rad

240 kg max

P 240 F

Stratificato fenolico, integrato nella schiuma in poliuretano. Carrellabilità massima Kg 240 per ruota rigida.

Stratified molded phenol integrated into the polyurethane foam. Maximum load 240 kg per rigid wheel.

Stratifié phénolique moulé, intégré dans la mousse en polyuréthane. Capacité maximum de 240 kg par roue rigide.

Gepresstes Phenollaminat, im PUR- Schaum integriert. Maximale Tragfähigkeit pro hartem Rad 240 Kg.

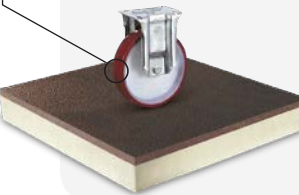

300 kg max

P 300 FR

Stratificato fenolico rinforzato, integrato nella schiuma in poliuretano. Carrellabilità massima Kg 300 per ruota rigida.

Reinforced stratified molded phenol integrated into the polyurethane foam. Maximum load 300 kg per rigid wheel.

Stratifié phénolique renforcé moulé, intégré dans la mousse en polyuréthane. Capacité maximum de 300 kg par roue rigide.

Verstärktes Gepresstes Phenollaminat, im PUR- Schaum integriert. Maximale Tragfähigkeit pro hartem Rad 300 Kg.

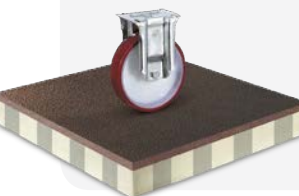

Sale di lavorazione - Food preparation areas - Salles de travail
Raum für Essenvorbereitung



Grande distribuzione - Supermarkets - Grande distribution
Supermärkte



Laboratori - Laboratories - Laboratoires - Laboratorien



Ristorazione - Restaurants - Restauration - Restaurants

MODULARITÀ Modularity - Modularité - Modulbauweise

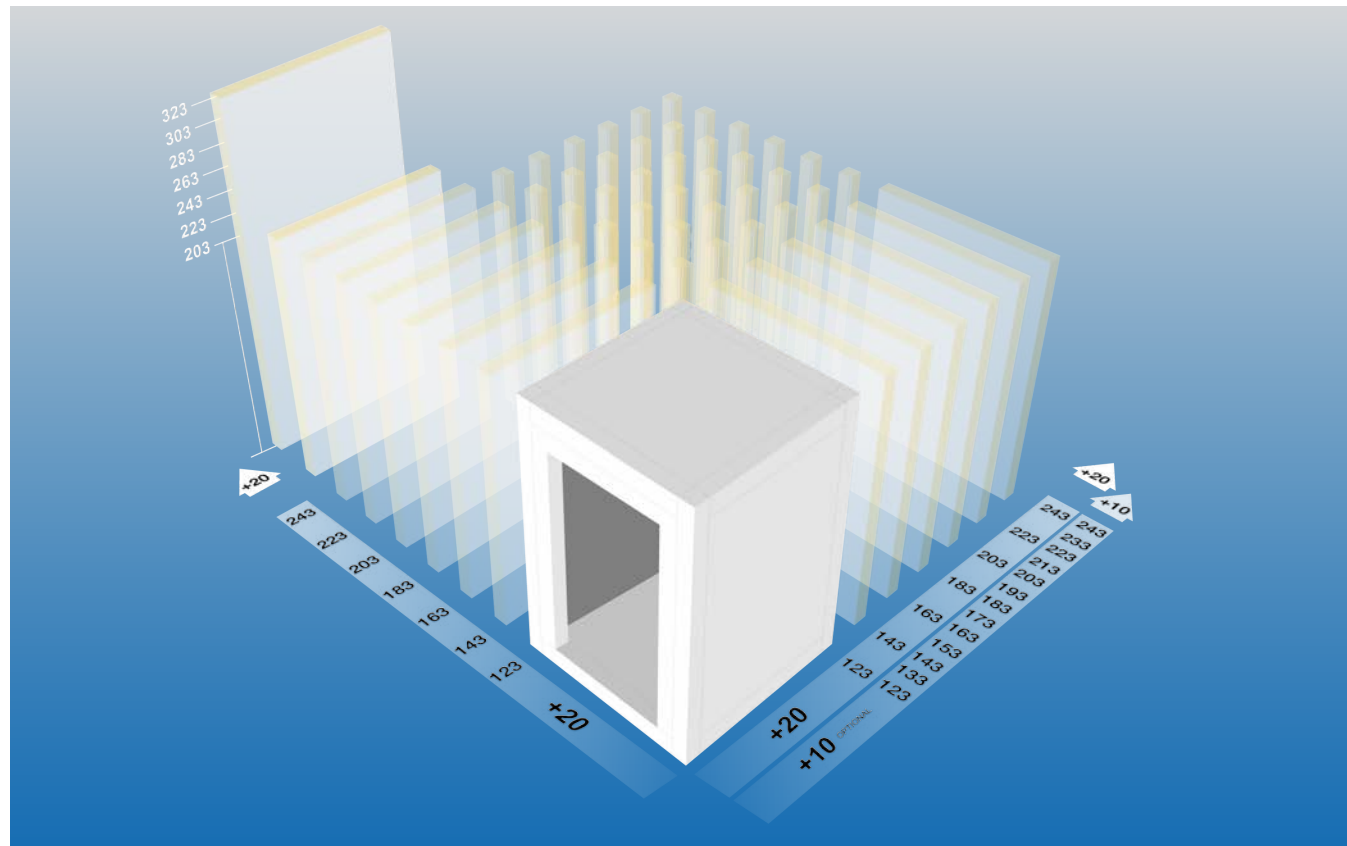

CERTIFICAZIONI Certification - Certifications - Zertifizierungen



EN 14509:2013
ETA 09/0066

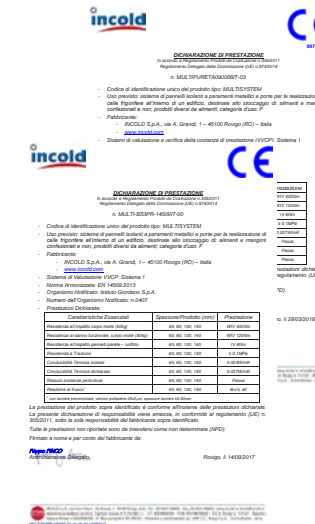

CE
ETA 09/0066

B-s3,d0
EN 13501-1

SOGLIE Threshold - Seuils - Schwellen

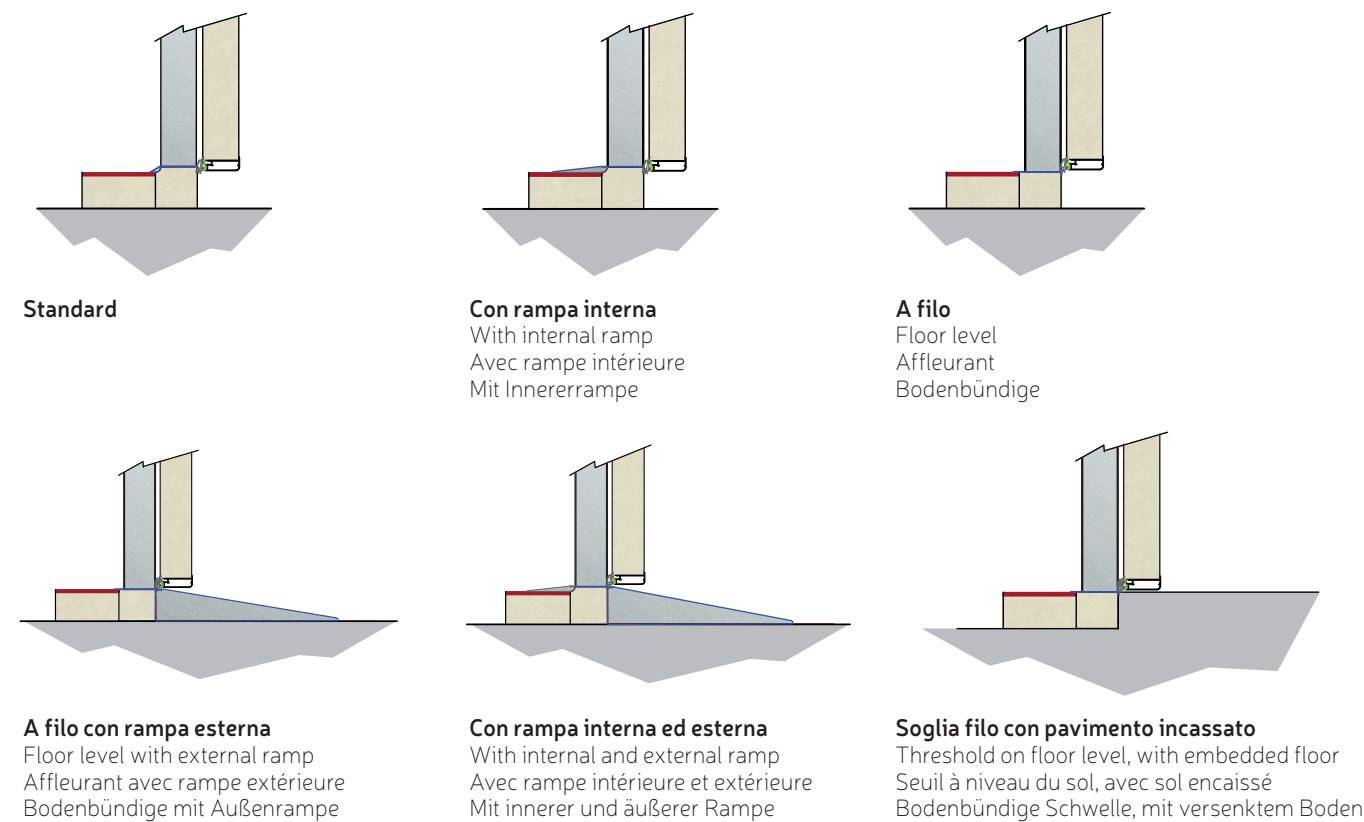

PORTE A VETRO Glass doors - Portes vitrées - Glastüren



CE-MULTI

Porte su cerniera Multisystem

Multisystem hinged doors

Portes pivotantes sur charnières Multisystem

Multisystem Flügeltüren



Il pannello vano porta è dotato perimetralmente di **ganci eccentrici di serraggio**, che ne consentono il montaggio, come un qualsiasi pannello di parete.

The door panel is fitted around the outer edge with **camlock fasteners**, like any wall panel, using the camlocks.

Le panneau de porté est muni de **crochets excentriques de serrage** périphériques qui permettent son montage comme tout panneau de parois.

Das Türpaneel ist am gesamten Umfang mit **Exzenterhaken zum Spannen** ausgestattet, die die eine Montage, wie alle andere Wandpaneele, ermöglichen.



Battente contornato da profilo in alluminio anodizzato, lungo il cui perimetro è alloggiata speciale guarnizione che garantisce la tenuta termica.

The **leaf** is lined with a profile in anodized aluminum and a special gasket is fitted around the edge to ensure a thermal seal.

Battant entouré d'un profil en aluminium anodisé avec le long de son périmètre un joint spécial qui garantit l'isolement thermique.

Türflügel mit Profil aus Eloxaluminium, mit Spezialdichtung entlang des Umfangs zur perfekten Thermodichtung.



Cerniere in materiale plastico composito, munite di rampa elicoidale, registrabili in altezza mediante vite di registro.

Hinges in a plastic compound material with spiral ramp, height adjustable with screws.

Charnières en matière plastique composite, munies de rampe hélicoïdale, réglables en hauteur par vis de réglage.

Spiralscharniere aus Kunststoffverbundmaterial, mit Justierschraube höhenstellbar.



Maniglia in materiale plastico composito, con chiusura a chiave e sblocco interno di sicurezza.

Handle in plastic compound material, with lock and key, and inside safety release.

Poignée en matière plastique composite, avec fermeture à clé et déblocage de sécurité intérieur.

Griff aus Kunststoffverbundmaterial, mit Schlüsselverriegelung und interner Sicherheitsentriegelung.

Options



Passaggio guidovia

Rail passage
Passage de rail
Laufschienedurchführung



Oblò rettangolare completo di vetro 300 x 600 H

Oval porthole 300 x 600 H
Hublot ovale 300 x 600 H
Ovales Sichtfenster 300 x 600 H



Maniglione antipanico

Anti-Panic bar
Barre anti-panique
Antipanikhebel

Dimensions mm

Luce netta Clear passage Passage libre Lichte durchgang		Pannello vano porta Door panel Panneaux de porte Tür paneel					
L	H	A	B				
			2000	2200	2400	2800	3200
600	1900	800	x	x	x	x	x
600	2000	800		x	x	x	x
700	1900	1200	x	x	x	x	x
700	2000	1200		x	x	x	x
800	1900	1200	x	x	x	x	x
800	2000	1200		x	x	x	x
950	1900	1200	x	x	x	x	x
950	1900 + P.G 200 x 400				x		
950	2000	1200		x	x	x	x
950	210 + P.G 200 x 560					x	x
950	2200	1200			x	x	x
1200	1900	1600	x	x	x	x	x
1200	2000	1600		x	x	x	x
1200	2200	1600			x	x	x

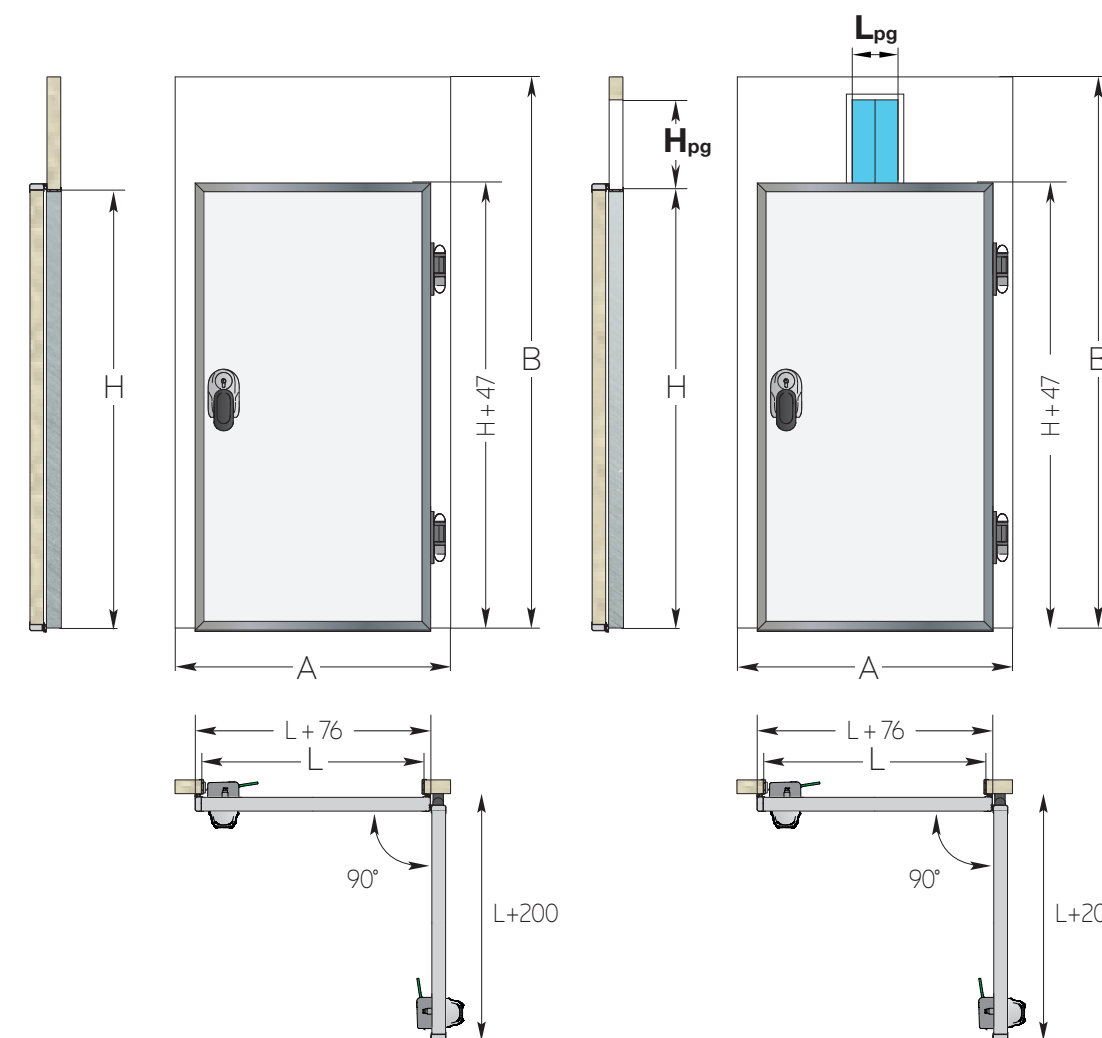

SC-MULTI

Porte scorrevoli Multisystem
Multisystem sliding doors
Portes coulissantes Multisystem
Multisystem Schiebetüren



Il pannello vano porta è dotato perimetralmente di **ganci eccentrici di serraggio**, che ne consentono il montaggio, come un qualsiasi pannello di parete.

The door panel is fitted around the outer edge with **camlock fasteners**, like any wall panel, using the camlocks.

Le panneau de porté est muni de **crochets excentriques de serrage** périphériques qui permettent son montage comme tout panneau de parois.

Das Türpaneel ist am gesamten Umfang mit **Exzenterhaken zum Spannen** ausgestattet, die die eine Montage, wie alle andere Wandpaneel, ermöglichen.



Battente contornato da profilo in alluminio anodizzato, lungo il cui perimetro è alloggiata speciale guarnizione che garantisce la tenuta termica.

The **leaf** is lined with a profile in anodized aluminum and a special gasket is fitted around the edge to ensure a thermal seal.

Battant entouré d'un profil en aluminium anodisé avec le long de son périmètre un joint spécial qui garantit l'isolement thermique.

Türflügel mit Profil aus Eloxaluminium, mit Spezialdichtung entlang des Umfangs zur perfekten Thermodichtung.

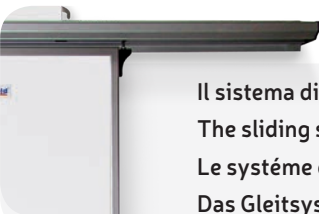

Il **sistema di scorrimento** (guida + carrello) è realizzato interamente in alluminio anodizzato.

The **sliding system** (guide + carriage) is made entirely of anodized aluminium.

Le **système de coulissement** (guide + chariot) est entièrement réalisé en aluminium anodisé.

Das **Gleitsystem** (Schiene + Schlitten) besteht vollständig aus Eloxaluminium.

Maniglia esterna a leva, maniglia interna a rotazione.
External lever **handle**, Inside rotation handle.
Poignée extérieure à levier, **Poignée** intérieure à rotation.
Außen **Griff** zu Hebel, Innen Griff zu Umdrehung



Dispositivi di guida inferiore in acciaio inox.

Lower rail system in stainless steel.

Dispositifs de rail inférieur en acier inox.

Untere Gleitvorrichtungen aus Edelstahl.

Zoccolo di compensazione nelle versioni con pavimento.
Compensations baseboard in versions with floor.
Seuil de compensation dans les versions avec sol.
Ausgleichssockel bei den Ausführungen mit Boden.

Options



Serratura con chiave
Key lock
Serrure à clé
Schloss mit Schlüssel



Oblò rettangolare completo di vetro 300 x 600 H
Oval porthole 300 x 600 H
Hublot ovale 300 x 600 H
Ovales Sichtfenster 300 x 600 H

Dimensions mm

Luce netta Clear passage Passage libre Lichte durchgang		Pannello vano porta Door panel Panneaux de porte Tür paneel						
L	H	P	X	HP				
				2000	2200	2400	2800	3200
600	1800	800	650	x				
600	1900	800	650		x	x	x	x
600	2000	800	650		x	x	x	x
700	1800	1200	600	x				
700	1900	1200	600		x	x	x	x
700	2000	1200	600		x	x	x	x
800	1800	1200	750	x				
800	1900	1200	750		x	x	x	x
800	2000	1200	750		x	x	x	x
950	1800	1200	975	x				
950	1900	1200	975		x	x	x	x
950	2000	1200	975		x	x	x	x
950	2200	1200	975			x	x	x
1200	1800	1600	1150	x				
1200	1900	1600	1150		x	x	x	x
1200	2000	1600	1150		x	x	x	x
1200	2200	1600	1150			x	x	x
1400	2200	1600	1350			x	x	x

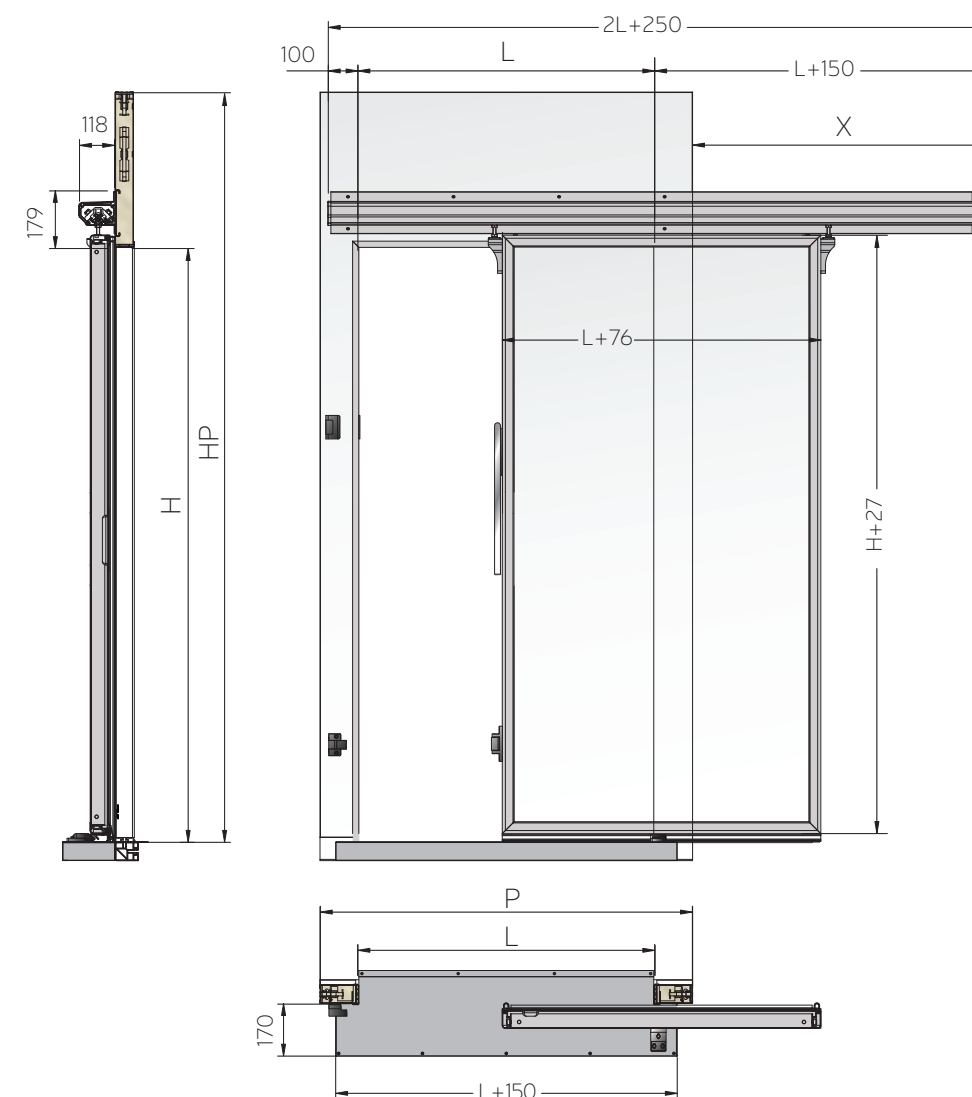

CELLE DIVISE IN PIÙ LOCALI Rooms with several partitions Chambres divisées en plusieurs locaux - Kühlzellen In mehrere Räume geteilt



Applicazione divisorio non modulare nella cella con stessa temperatura.

Application of non-modular dividing wall in room with the same temperature.

Application cloison non modulaire dans la chambre avec la même température.

Anbringung einer FLEXIBLEN Trennwand in der Kühlzelle mit der gleichen Temperatur.

DETTAGLI E POSSIBILITÀ DI ACCOPPIAMENTO Details and possibilities of connection

Accoppiamento agganciato di celle con divisorio modulare.

Connection with camlocks of rooms with modular dividing wall.

Accouplement accroché de chambres avec cloison modulaire.

Hakenverbindung von Zellen mit stationärer Trennwand.

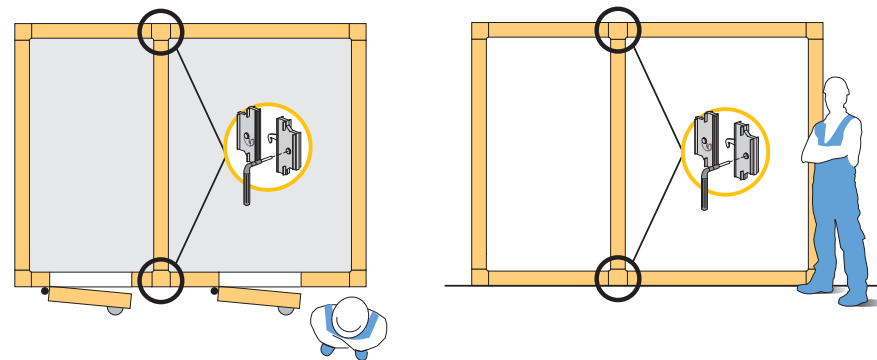

Détails et possibilité d'accouplement - Details und Verbindungsmöglichkeiten

Accoppiamento agganciato e modulare di celle con pavimento e altezze diverse

Modular connection with camlocks of rooms with floor and different heights.

Accouplement accroché et modulaire de chambres avec sol et hauteurs différentes.

Modulare Hakenverbindung von Zellen mit Bodenpaneelen und verschiedenen Höhen.

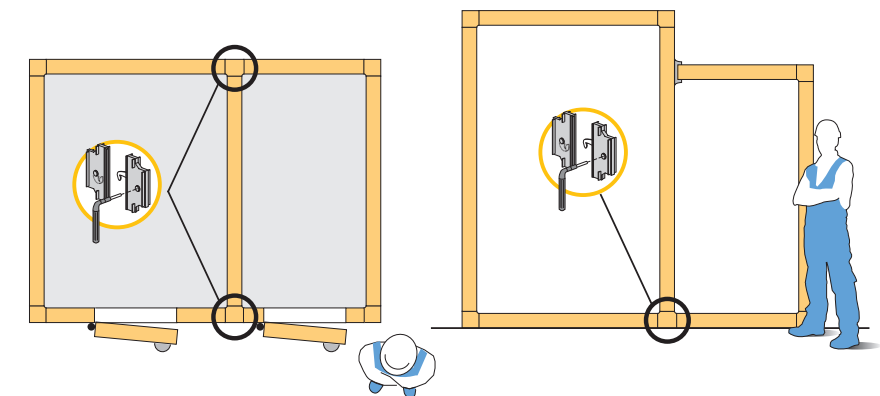

Accoppiamento agganciato e modulare di celle con pavimento e di diverso spessore.

Modular connection with camlocks of rooms with floor and of different thickness.

Accouplement accroché et modulaire de chambres avec sol et d'épaisseur différente.

Modulare Hakenverbindung von Zellen mit Bodenpaneelen und verschiedenen Stärken.

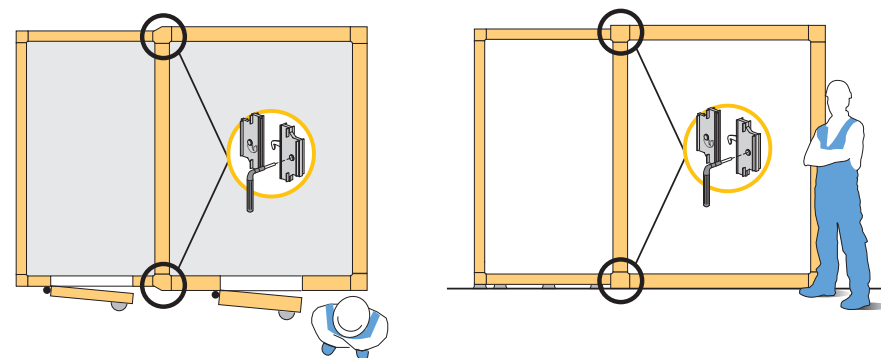

Accoppiamento agganciato e modulare di celle di spessore e altezze diverse con e senza pavimento

Modular connection with camlocks of rooms with different heights and thicknesses with and without floor.

Accouplement accroché et modulaire de chambres d'épaisseur et hauteurs différentes avec et sans sol.

Modulare Hakenverbindung von Zellen mit verschiedenen Stärken und Höhen, mit oder ohne Bodenpaneelen.

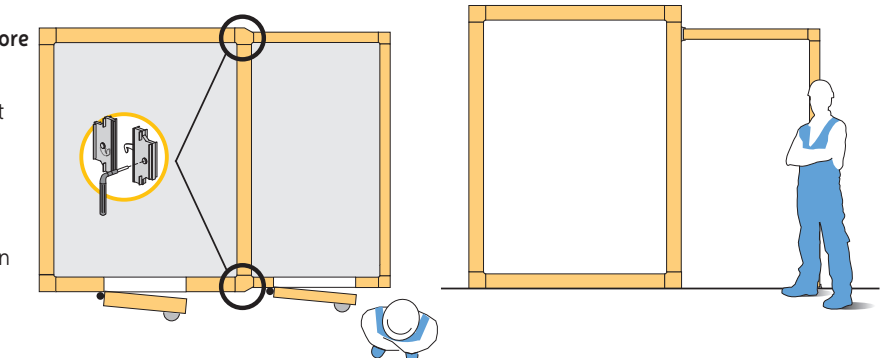

Armadi Frigoriferi Componibili
Refrigerated cabinet elements
Armoires Frigorifiques à Éléments
Zusammenbaubare Kühlschränke

CE
ETA 09/0066

B-s3,d0
EN 13501-1

Armadi Frigoriferi Componibili,
unione mediante ganci eccentrici.
Ideali per l'utilizzo in spazi ristretti
quali ristoranti, cucine, mense e
laboratori.

Refrigerated cabinet elements,
can be joined using camlocks. Ideal for
restaurants, kitchens, canteens and
laboratories where space is at a pre-
mium.

Armoires Frigorifiques à Éléments,
union par crochets excentriques.
Idéales pour l'utilisation dans des
espaces étroits comme restau-
rants, cuisines, cantines et labora-
toires.

Zusammenbaubare Kühlschränke,
Zusammenbau mit Exzenterhaken.
Ideal zum Einsatz in kleinen Räumen
wie Restaurants, Küchen, Mensen
und Labors.

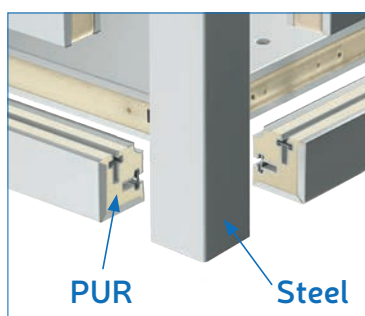

UNIONE CON GANCI ECCENTRICI A DOPPIO EFFETTO
Connection with dual effect camlocks
Union par crochets excentriques à double effet
Verbindung mit exzentrischen Doppelleffekthaken

60 mm
100 mm
2 SPESSORI
2 Thicknesses
2 Epaisseurs
2 Stärken



SPORTELLI SPORGENTI
Protruding half doors
Portillons en saillie
hervorstehende Entnahmeluken

ISO: mm 60-100
MODUL: mm 800
H int.: mm 2030
Isolamento - Insulation - Isolation - Isolierung
PUR - 41 kg/m³ - λ 0,023 W/mK
Reaction to fire B s3 d0 standard



PORTE Doors - Portes - Türen
610x1700 mm (Luce netta - Net opening - Passage libre - Nettoöffnung)

SPORTELLI Half doors - Portillons - Entnahmeluken
610x800 mm (Luce netta - Net opening - Passage libre - Nettoöffnung)

per un facile inserimento su apposite guide, di ripiani grigliati cm 60 x 80 o teglie pasticceria cm 60 x 40 cm
for an easy insertion on special runners of wire shelves cm 60 x 80 or pastries trays 60 x 40 cm.
pour insertion facile, sur des guides appropriés, de tablettes en grille cm 60 x 80 ou de plats pour pâtisserie 60 x 40 cm.
um das leichte Einsetzen von Gitterauslagen 60 x 80 bzw. Konditorei-Behältern 60 x 40 cm auf den entsprechenden Schienen zu ermöglichen.

PIEDINI REGOLABILI
Adjustable feet
Pieds réglables
Einstellbare Füße

ANGOLI INTERNI ARROTONDATI R15
Rounded R15 internal corners
Angles intérieurs arrondis R15
Abgerundete Innenecken R15

DIMENSIONI Dimensions - Dimensions - Standardabmessungen

ISO 60 mm

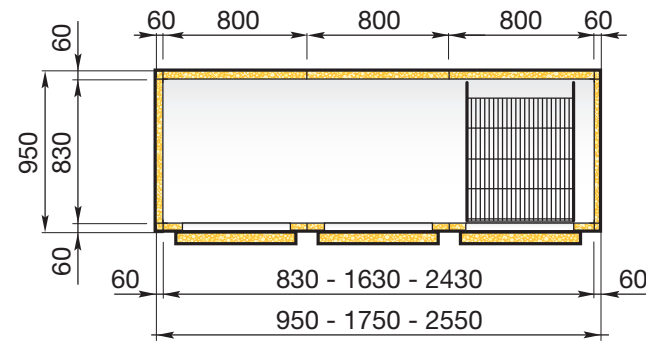
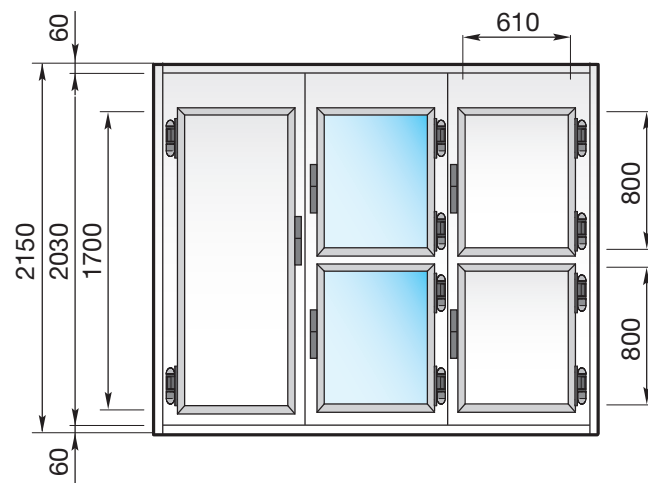

ISO 100 mm

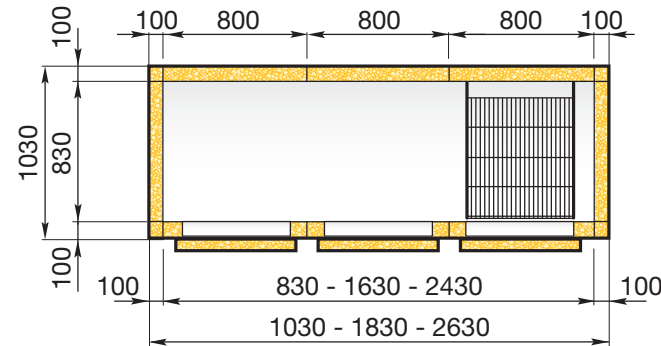
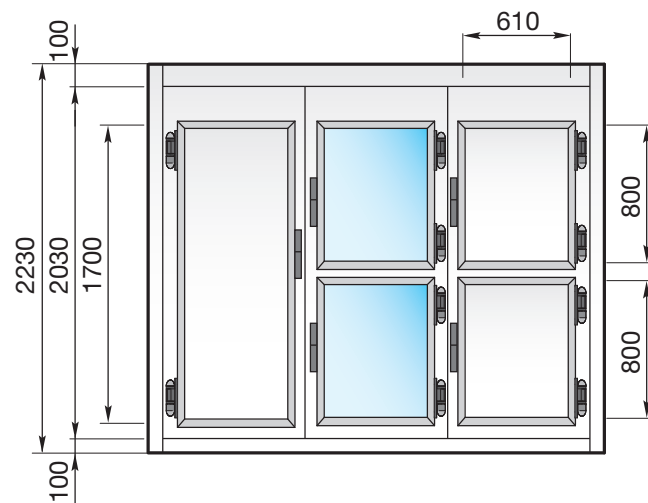

Options: RIVESTIMENTI Panel finishing - Revêtement - Beschichtung



PL
Lamiera Plasticata
Plasticized sheet metal
En tôle Plastifiée
Kunststoffbeschichtetes Stahlblech

Lamiera di acciaio zincato, plastificato con film in PVC rigido dello spessore di 120 micron bianco, atossico con pellicola protettiva.
Galvanized sheet steel with plastic coating in rigid white PVC 120 micron thick, non-toxic, with protective film.
Tôle d'acier galvanisée plastifiée avec film en PVC rigide d'épaisseur de 120 micron blanc, atoxique avec pellicule de protection.
Verzinktes Stahlblech, mit weißem, hartem, ungiftigem und 120 micron starkem PVC-Film plastifiziert, mit Schutzfilm.

IX
Lamiera Inox
Stainless steel sheet
Tôle Inox
Edelstahlblech

Lamiera INOX AISI 304, finitura scotch brite con pellicola protettiva.
AISI 304 stainless sheet steel, finished with Scotch-Brite treatment with protective film.
Tôle INOX AISI 304, finition SCOTCH BRITE avec pellicule de protection.
Blech aus CHROMNICKELSTAHL 1.4301, Scotch-Brite-Oberflächenführung mit Schutzfilm.

Options: ACCESSORI Accessories - Accessoires - Zubehör



60 x 80 cm

Griglie interne estraibili di acciaio zinco-cromato, posizionabili a passo 62 mm
Removable internal grilles in galvanised chrome-plated steel placed at 62 mm height steps
Grilles internes amovibles en acier zingué-chromé positionnables tous les 62 mm
Herausnehmbare Innenroste aus Stahldraht, jede 62 mm stellbar



Porte cieche e a vetri (a vetri solo per temperature positive)
Solid and glass doors (glass doors for positive temperature only)
Portes pleines et vitrées (vitrées seulement pour température positive)
blinde Türen und Glastüren (Glastüren nur für Normalkühlung)



Sportelli ciechi e a vetri (a vetri solo per temperature positive)
Solid half doors and glazed half doors (glazed for positive temperature only)
Portillons pleins et en verre (verre seulement pour température positive)
blinde oder verglaste Entnahmeluken (verglaste nur für Normalkühlung)



Illuminazione interna
Internal lighting
Eclairage intérieur
Innenbeleuchtung



Impianti frigoriferi a soffitto per temperature positive o negative.
Ceiling **refrigeration units** for negative and positive temperatures.
Installations frigorifiques au plafond pour températures positives et négatives.
Kühlanlagen zum Einbau als Deckenmodelle für Temperaturen über und unter 0 °C.

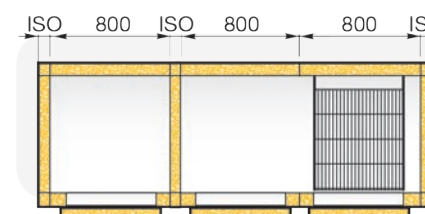

Divisori interni verticali
Vertical internal dividing walls
Cloisons verticales de séparation à l'intérieur
senkrechte Innere Trennwände

EASYRACK

Scaffalatura alluminio/polietilene
Shelving in aluminium and polythene
Rayonnage en aluminium et polythène
Regalsystem aus Aluminium und Polyäthylen



• **Montaggio rapido e veloce** - Easy and quickly fit assembly
Assemblage rapide et facile - Leicht und schnell Einbau

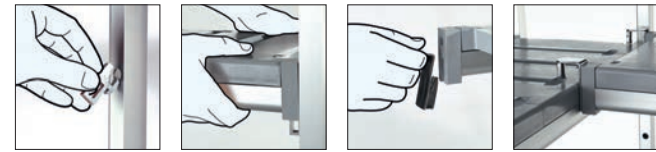

• **Composizione** - Composition - Composition - Zusammensetzung

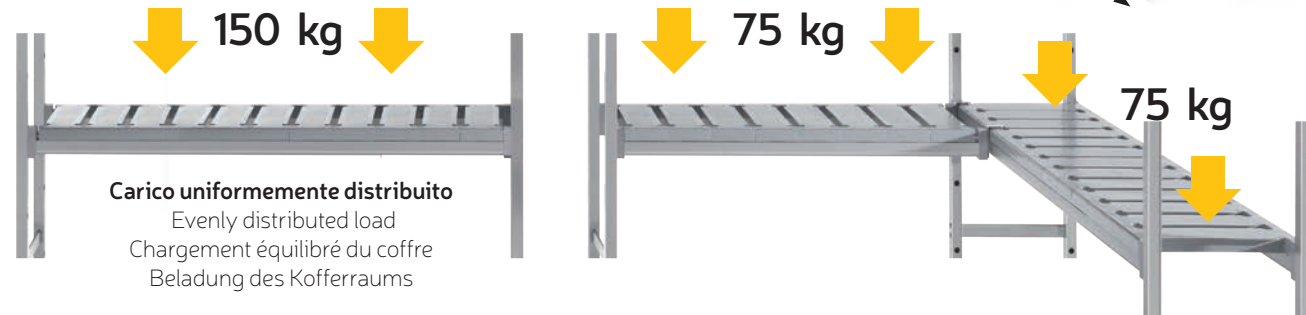

VETRATE TERMICHE Thermal glass - Verre thermique - Thermo-Verglasung

Mod. AD 70

Vetrata termiche caratterizzate da un telaio in PVC termosaldato
Insulated windows, featuring a PVC heat sealed frame
Double vitrage caractérisé par un châssis en PVC thermosoudé
Thermo-Fenster mit einem thermisch geschweißten PVC-Rahmen

Mod. ALU

Vetrata termica con telaio in alluminio anodizzato e vetro a singola camera
Thermal glass with anodised aluminum frame and single chamber glass
Verre thermique avec un cadre en aluminium anodisé et un verre à chambre unique
Thermo-Verglasung mit eloxiertem Aluminiumrahmen und Einkammerglas

Mod. FILO ALU 1C - FILO ALU 2C

Vetrata a filo - telaio in alluminio
Thermal window flush with the wall of the cold room - aluminium frame
Baie vitrée affleurante avec le parois de la CF - cadre en aluminium
wandbündiges Glasfenster - Rahmen aus aluminium

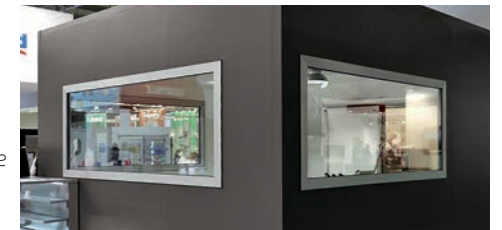

PANORAMA SHELF

Scaffalatura Panorama
Panorama shelving
Rayonnage pour boissons
Regalsystem drink

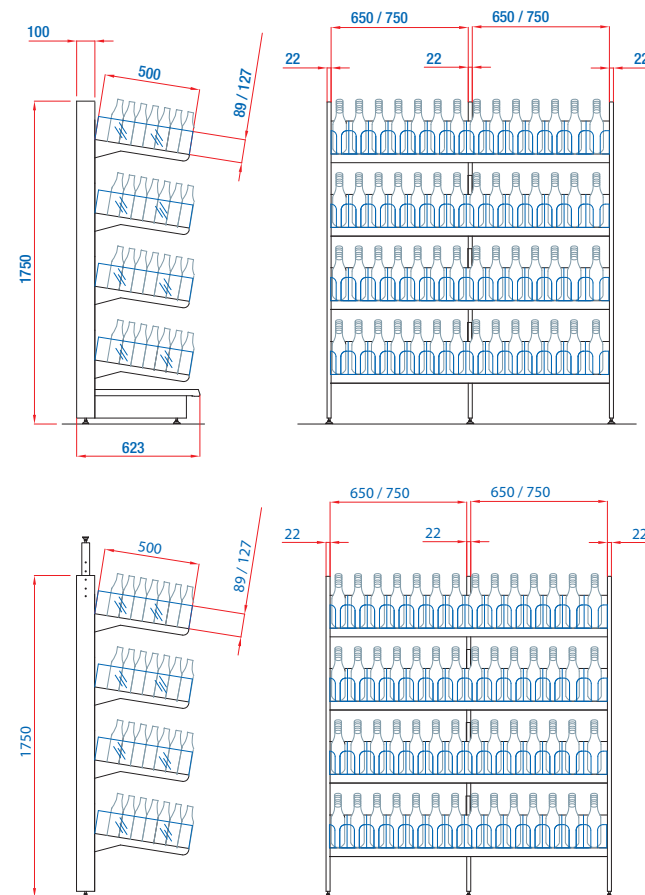

PLAFONIERA LED Ceiling light Led - Plafonnier Led - Deckenleuchte Led



Durable, Waterproof

20 W
1600 Lm
230 V 50 HZ

GRUPPI FRIGORIFERI Condensing units - Unités frigorifiques - Kälteanlagen

Model FA

Monoblocchi a parete accavallati
Saddle packaged units for cold rooms
Monoblocs cavaliers pour chambres froides
Huckepackaggregat



Model ST

Serie split
Split range
Série split
Serie Split



Model FT

Monoblocchi a tampone
Plug-in packaged units for cold rooms
Monoblocs à tampon pour chambres froides
Stopferaggregat



Model STS

Serie split con evaporatore statico
Split range with static evaporator
Série split avec évaporateur statique
Serie Split mit statischem Verdampfer



Model SF

Monoblocchi a soffitto
Packaged units, ceiling mounting installation
Monoblocs à plafond pour chambres froides
Deckenaggregat



Servizi - Services - Services - Serviceleistungen



SOLUZIONI DI TRASPORTO PERSONALIZZATE

Customized transport solutions
Solutions de transport personnalisées
kundenspezifische Transportlösungen



PREVENTIVI IN 48 ORE

48h quotations
Devis dans les 48 heures
Angebote in 48 Stunden



CONSEGNE RAPIDE IN TUTTO IL MONDO

Fast worldwide delivery
Livraisons rapides dans le monde entier
schnelle Lieferungen weltweit



ESECUZIONI PERSONALIZZATE

Customization
Exécutions personnalisées
Sonderanfertigungen

INCOLD S.p.A.

Via Grandi 1, 45100 Rovigo, Italy
incold.it | incoldactive.it

