

Miss Baker® PRO: technical data

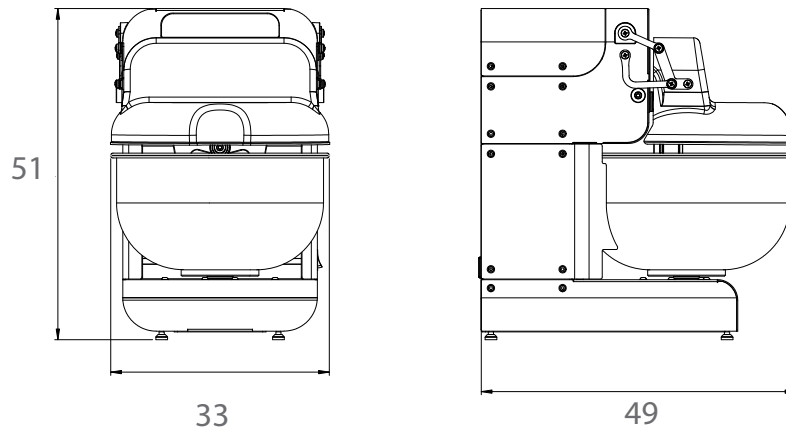

Maximum dimensions (cm) of Miss Baker® PRO.

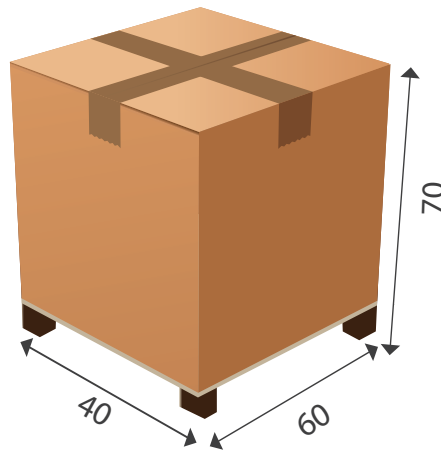

Miss Baker® Pro	
Flour capacity	0,5 - 1,8 kg
Kneading capacity*	0,8 - 4 kg**
Bowl capacity	10 liters
Dimensions of bowl	Ø 32 - h 18
Voltage	230 V single-phase
Power	500 W
Speed of the arms	from 35 to 70 strokes/min
Kneading machine dimensions LxPxH (cm)	33x49x51
Dimensions with packaging LxPxH (cm)	40x60x70
Kneading machine weight / Weight with packaging	36 kg / 48 kg
Code	MS0323059

* The kneading capacity refers to a flour / liquid ratio of 1: 0.6 and may vary according to the recipe
 ** The maximum kneading capacity refers to very hydrated doughs and for large leavened products. For hard doughs - hydration less than 55% - such as egg pasta and sourdough, reduce the maximum flour capacity by 50%.